

## ABRASIVE METERING AND AIR VALVES

### Abrasive Metering Valves

Description	Stock No.	Price	Disc.	Wt.	Description	Stock No.	Price	Disc.	Wt.
FSV .....	02427	306.00	Q	14	Sentinel				
LMV for Soft King & Pool Pal.....	99555	287.00	D	2	with ACS .....	20508	870.00	D	23
LPV for Lo-Pot.....	05680	348.00	D	10	without ACS .....	20608	840.00	D	23
MPV Pinch valve, manual ..	04321	427.00	D	9	fine-mesh without ACS ..	21439	870.00	D	23
MSV for 1028 and 1042 machines .....	01247	168.00	D	2	<b>Air Valves for Pressure-Hold Remotes</b>				
PVR grit .....	04319	730.00	D	23	ACE air valve, 1-1/4"				
Quantum					with fitting .....	24044	462.00	D	8
AQV auto grit, 1-1/4" .....	24447	750.00	D	18	(see drawing in Remote Controls section)				
AQV-H auto grit, 1-1/4" ..	27525	780.00	D		ACE air valve, 1-1/2"				
AQV auto grit, 1-1/2" .....	25281	760.00	D		with fitting .....	25289	526.00	D	8
MQV manual grit .....	22845	411.00	Q	8					

### CLEMCO ABRASIVE METERING VALVES

#### Application Guide

Model/ Description	For use with:	Stock No.	Manual or Pneumatic	Remote Control Type	Applications (abrasives/media)	Alternate Use
FSV Flat Sand Valve	Classic blast machine 2 cuft and larger	02427	Manual	Pressure Release	Use with expendable mineral & slag abrasives; plastic media, metallic media not recommended.	
MQV Manual Quantum Valve	Contractor & Classic machines	22845	Manual	Pressure Release	Use with all common abrasives; mineral, slag, or metallic .	
AQV Auto Quantum Valve	All blast machines with pressure-hold remotes or ACS. Job order blast machines (except AeroLyte)	24447	Pneumatic	Pressure-hold and Abrasive cut-off sys.	Use with most media; requires pressures above 80 psi. Not recom- mended for lightweight media.	
AQV-H Auto Quantum Valve Heavy-duty	All blast machines with pressure-hold remotes or ACS. Job order blast machines (except AeroLyte)	27525	Pneumatic	Pressure-hold and Abrasive cut-off sys.	Use with most media; requires pressures above 80 psi. Use for high production applications. Not recommended for lightweight media.	
LMV Light Weight Media Valve	Soft King and Pool Pal machines	99555	Manual	Pressure Release	Use with baking soda, fine-mesh alumina silicate, kieserite, glass bead agricultural media or similar. Valve has 1/2" NPT connection.	
LPV Lo-Pot Valve	Lo-Pot machines	05680	Manual	Pressure Release	Use with expendable mineral and slag abrasives.	
MPV Pinch Tube Valve	Not standard on any machine	04321	Manual	Pressure Release	Use with coarse steel grit (G-25 & larger) and #10 and larger nozzles.	2 cuft and larger Classic machines
MSV Valve	0.5 & 1 cuft Classic machines	01247	Manual	Pressure Release	Use with expendable mineral and slag abrasives. Not recommended for use with fine mesh or glass.	Machines with 1/2" piping
Sentinel Valve	Blast machines with pressure release remotes or ACS; industrial blast machines	20508	Pneumatic	Pressure Release	ACS applications; all media. Use with abrasives coarser than 50 mesh; requires 50 to 70 psi to fully open plunger.	2 cuft and larger Classic machines
Sentinel Valve without ACS	Blast machines with pressure release remotes; industrial blast machines	20608	Pneumatic	Pressure Release	All media. Use with abrasives coarser than 50 mesh. Requires 50 to 70 psi to fully open plunger.	2 cuft and larger Classic machines
Sentinel Valve fine mesh model	Pressure cabinets and Super Comet	21439	Pneumatic	Pressure Release and ACS	Only for abrasives 50 mesh or finer. Features a urethane covered metering plate.	

# FSV ABRASIVE METERING VALVE

Description	Stock No.	Price	Disc.	Wt.	Description	Stock No.	Price	Disc.	Wt.
<b>(-) FSV metering valve, complete</b> .....02427	<b>306.00</b>	<b>Q</b>	<b>14</b>		14. Stud .....02436	<b>8.50</b>	<b>D</b>	<b>&lt;.5</b>	
1. Upper body .....02422	<b>132.00</b>	<b>D</b>	<b>2.5</b>		15. Packing gland .....02437	<b>5.50</b>	<b>D</b>	<b>&lt;.5</b>	
2. Valve .....02423	<b>104.00</b>	<b>D</b>	<b>1</b>		16. O-ring, 7/8" OD .....21165	<b>1.50</b>	<b>D</b>	<b>&lt;.5</b>	
3. Gasket, rubber, 2 required .....02424	<b>8.50</b>	<b>D</b>	<b>&lt;.5</b>		17. Gasket, shaft .....02439	<b>5.50</b>	<b>D</b>	<b>&lt;.5</b>	
4. Disc-stainless .....02425	<b>96.00</b>	<b>D</b>	<b>2.5</b>		18. Inspection plate .....02440	<b>19.00</b>	<b>D</b>	<b>&lt;.5</b>	
5. Lower body .....02426	<b>100.00</b>	<b>D</b>	<b>1.5</b>		19. Cap screw 5/16-NC x 1" hex head .....03152	<b>1.00</b>	<b>D</b>	<b>&lt;.5</b>	
6. Metering handle, heavy duty .....20498	<b>45.00</b>	<b>D</b>	<b>2</b>		20. Wing nut, 5/16-NC .....03213	<b>1.00</b>	<b>D</b>	<b>&lt;.5</b>	
7. Cap screw, 1/4-NC x 1-1/4" hex head .....03054	<b>0.50</b>	<b>D</b>	<b>&lt;.5</b>		21. O-ring .....01990	<b>3.50</b>	<b>D</b>	<b>&lt;.5</b>	
8. Wing nut, 1/4-NC .....03113	<b>1.00</b>	<b>D</b>	<b>&lt;.5</b>		22. Nipple, 1-1/2" x close .....01791	<b>16.00</b>	<b>D</b>	<b>&lt;.5</b>	
9. Handle bolt spacer .....02431	<b>9.00</b>	<b>D</b>	<b>&lt;.5</b>		23. Wye, standard 1-1/4" .....01818	<b>32.50</b>	<b>D</b>	<b>2</b>	
10. Valve handle pin .....20246	<b>2.00</b>	<b>D</b>	<b>&lt;.5</b>		24. Nipple, 1-1/4" x 5" .....01721	<b>7.50</b>	<b>D</b>	<b>.5</b>	
11. Gauge unit .....02433	<b>25.00</b>	<b>D</b>	<b>&lt;.5</b>		25. Nut, 1/2-NC hex .....03511	<b>1.00</b>	<b>D</b>	<b>&lt;.5</b>	
12. Set screw, 1/4-NC x 1/2" square head ...03080	<b>1.00</b>	<b>D</b>	<b>&lt;.5</b>		26. Cap screw, 1/2-NC x 1-3/4" hex head .....03455	<b>2.50</b>	<b>D</b>	<b>&lt;.5</b>	
13. Spring, compression .....01982	<b>9.00</b>	<b>D</b>	<b>&lt;.5</b>		27. Washer, 1/4" flat .....03116	<b>1.00</b>	<b>D</b>	<b>&lt;.5</b>	
					28. Hitch pin .....20245	<b>1.00</b>	<b>D</b>	<b>&lt;.5</b>	

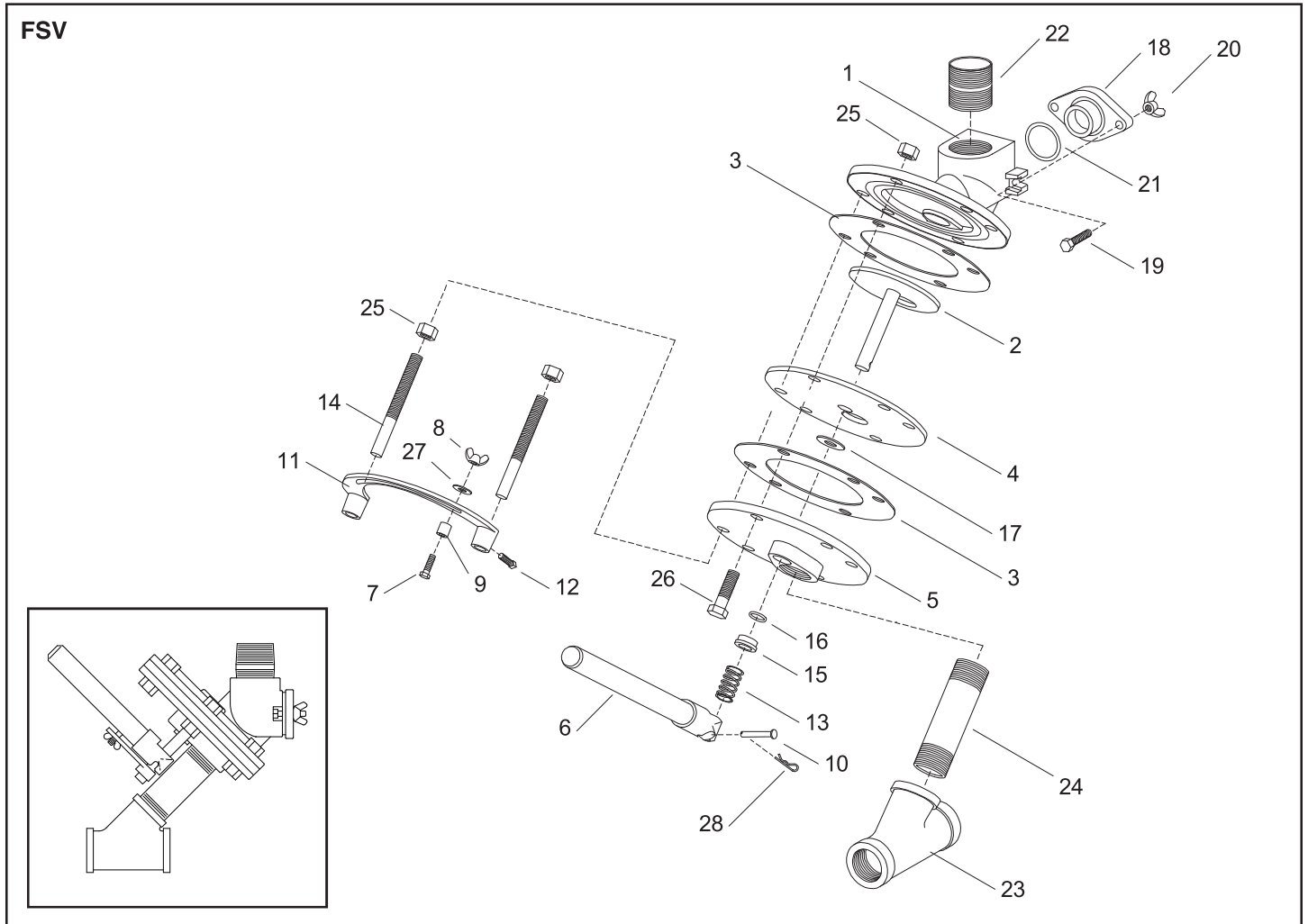

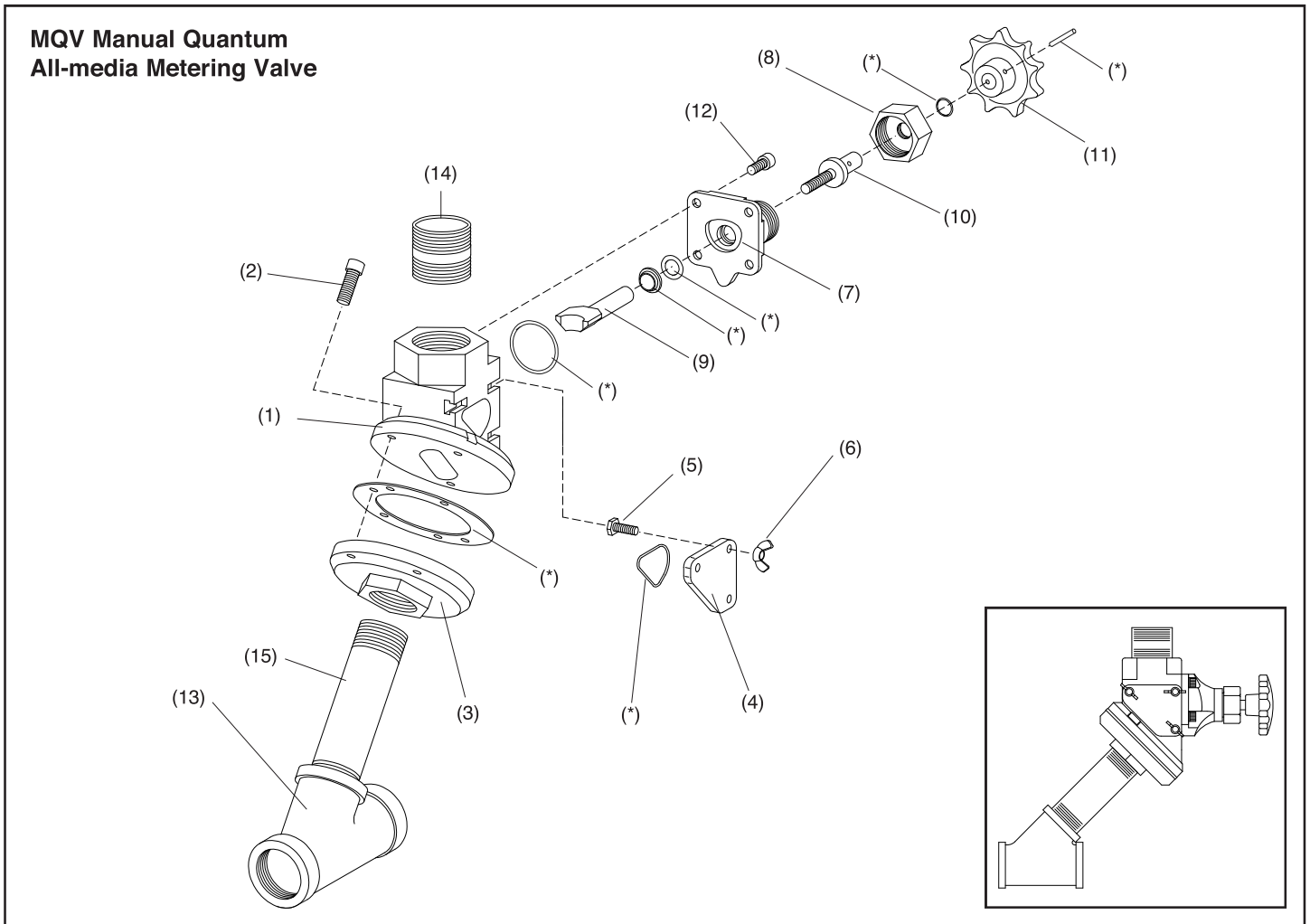

Description	Stock No.	Price	Disc.	Wt.
<b>(-) MQV manual Quantum metering valve complete</b> .....	22845	<b>411.00</b>	Q	8
(*) Service Kit Quantum Metering segment .....	22854	<b>26.50</b>	D	<.5
(see * on drawing)				
1. Adaptor flange w/insert.....	21314	<b>103.00</b>	D	2
2. Screw, 3/8-NC x 1" socket head.....	22655	<b>1.00</b>	D	<.5
3. Lower body.....	22621	<b>57.00</b>	D	1
4. Inspection plate.....	22620	<b>20.50</b>	D	<.5
5. Screw, 1/4-NC x 3/4" hex head cap, .....	03052	<b>1.00</b>	D	<.5
6. Wing nut, 1/4-NC .....	03113	<b>1.00</b>	D	<.5

Description	Stock No.	Price	Disc.	Wt.
7. Housing, knob .....	22761	<b>48.00</b>	D	<.5
8. Nut, knob housing .....	22762	<b>38.00</b>	D	<.5
9. Metering plate and shaft.....	22763	<b>85.00</b>	D	<.5
10. Metering screw .....	22764	<b>52.00</b>	D	<.5
11. Knob, adjustment .....	22766	<b>40.00</b>	D	<.5
12. Screw, 5/16-NC x 3/4" socket head .....	22767	<b>1.00</b>	D	<.5
13. Wye, 1-1/4" .....	01818	<b>32.50</b>	D	2
14. Nipple, 1-1/2" x 2" .....	01840	<b>12.50</b>	D	<.5
15. Nipple, 1-1/4" x 5-1/2" .....	01874	<b>10.50</b>	D	1
(-) Conversion kit: Quantum rack & pinion to knob .....	22841	<b>242.00</b>	D	.5



# AQV AUTO QUANTUM ALL MEDIA METERING VALVE

OM 22565

Description	Stock No.	Price	Disc.	Wt.
<b>(-) AQV - Auto Quantum grit valve</b> with metering assembly and installation fittings includes 01718, 01791, 01818, 01993, and 02513 ...	24447	<b>750.00</b>	D	18
1. Cover, cylinder .....	21317	<b>75.00</b>	D	1
2. Stop, piston .....	21323	<b>33.00</b>	D	<.5
3. Piston, rubber piston-cup w/bushing.....	21329	<b>63.00</b>	D	1
4. Body .....	21349	<b>381.00</b>	D	3
5. Plunger, for grit valve .....	21326	<b>99.00</b>	D	1
6. Wear sleeve .....	21342	<b>73.00</b>	D	<.5
7. *Seat, urethane .....	21344	<b>29.50</b>	D	<.5
8. *Gasket, flange.....	21322	<b>10.50</b>	D	<.5
9. Flange, thrd outlet .....	21319	<b>77.00</b>	D	1
10. *Felt disc. ....	22820	<b>2.50</b>	D	<.5
11. Screw, 3/8-NC x 1" socket head .....	22655	<b>1.00</b>	D	<.5
12. Screw, 5/16-NC x 1-3/4" socket head .....	21321	<b>11.00</b>	D	<.5
13. Screw, 5/16-NC x 1" socket head .....	21318	<b>1.00</b>	D	<.5
14. Spring .....	20600	<b>50.00</b>	D	1.5

Description	Stock No.	Price	Disc.	Wt.
15. Wye, 1-1/4".....	01818	<b>32.50</b>	D	<.5
16. *O-ring, 1-1/2" ID .....	20267	<b>2.00</b>	D	<.5
17. *Wiper, plunger .....	20268	<b>22.00</b>	D	<.5
18. *O-ring, 3-1/64" ID.....	22609	<b>1.50</b>	D	<.5
19. *Roll pin, 1/8" x 1/2" .....	21164	<b>1.00</b>	D	<.5
20. Nipple, 1-1/2" x close .....	01791	<b>16.00</b>	D	<.5
21. Nipple, 1-1/4" x 2" .....	01718	<b>5.00</b>	D	<.5

Note: following parts not needed with new flange (21319)

(-) Quantum valve actuator service kit.....	24446	<b>49.00</b>	D	1.5
------------------------------------------------	-------	--------------	---	-----

(see page 45 for contents of service kit)

(-) *U-seal, 3-1/2" ID (used w/ alum piston) .....	22606	<b>9.50</b>	D	<.5
-------------------------------------------------------	-------	-------------	---	-----

Note: Rubber piston cup with bushing (21329) replaces aluminum piston (21329) with u-seal. U-seal (22606) is still available.

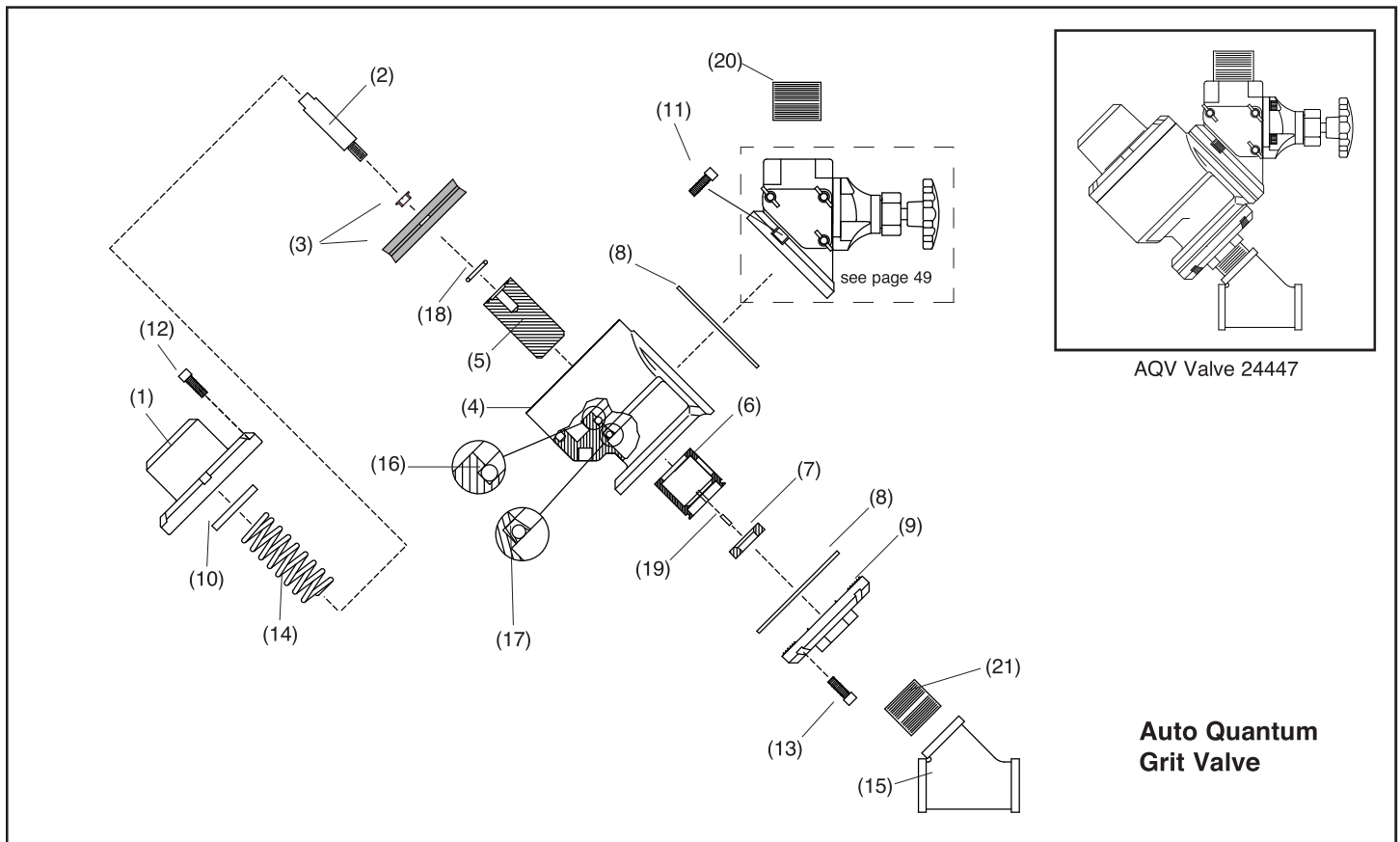

## AQV-H AUTO QUANTUM ABRASIVE METERING VALVE

### AQV-H Auto Quantum Actuator

Description	Stock No.	Price	Disc.	Wt.
(-) <b>AQV-H valve</b>				
w/fittings .....	27525	<b>780.00</b>	D	
without fittings .....	27520	<b>750.00</b>	D	
(-) Actuator assembly .....	27620	<b>554.00</b>	D	
(*) Service kit, Quantum actuator .....	24446	<b>49.00</b>	D	
(-) Conversion kit, AQV to AQV-H .....	27621	<b>365.00</b>	D	
1. Cover, cylinder .....	21317	<b>75.00</b>	D	
2. Stop, piston .....	21323	<b>33.00</b>	D	
3. Piston cup, AQV-H .....	20515	<b>34.50</b>	D	
4. Valve body, actuator .....	21349	<b>381.00</b>	D	
5. Plunger .....	27523	<b>100.00</b>	D	
6. Wear sleeve, urethane ..	27521	<b>90.00</b>	D	
7. Flange, threaded outlet w/retaining ridge .....	21319	<b>77.00</b>	D	
8. Screw, 5/16-NC x 1-3/4" socket head .....	21321	<b>11.00</b>	D	
9. Screw, 5/16-NC x 1" socket head .....	21318	<b>1.00</b>	D	
10. Spring, 4" .....	27524	<b>47.00</b>	D	
11. Adaptor, 1/4" NPT elbow ..	02513	<b>6.50</b>	D	
12. Petcock, 1/4" NPT .....	01993	<b>17.00</b>	D	
13. Screw, 3/8-NC x 1" socket head .....	22655	<b>1.00</b>	D	
14. Nipple, 1-1/2" x close, schedule 80 .....	01791	<b>16.00</b>	D	
15. Nipple, 1-1/4" x 2" .....	01718	<b>5.00</b>	D	
16. Wye, 1-1/4" NPT .....	01818	<b>32.50</b>	D	
17. Metering assembly .....	24587	<b>299.00</b>	D	
18. Seat, urethane AQV .....	21344	<b>29.50</b>	D	
19. Wye, 1-1/2" NPT .....	01819	<b>49.00</b>	D	

Description	Stock No.	Price	Disc.	Wt.
20. Bushing, 1-1/2" NPT x 1-1/4" NPT .....	01805	<b>10.00</b>	D	
21. Nipple, 1-1/4 x close HD .	01854	<b>9.50</b>	D	

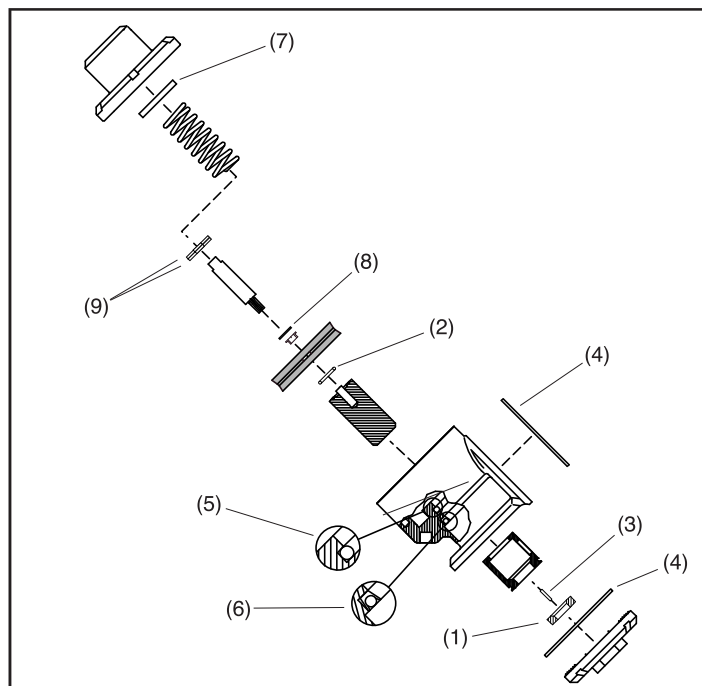
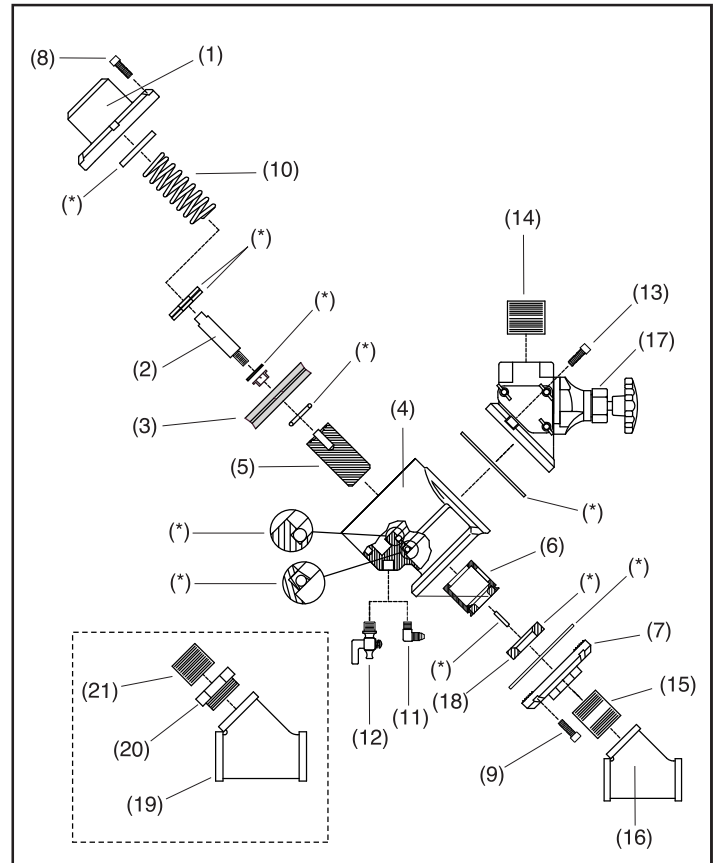

### Quantum Actuator Assembly,

Service Kit .....	24446	<b>49.00</b>	D	1.5
-------------------	-------	--------------	---	-----

Item	Description	Stock No.	AQV	AQV-H
1.	Seat, urethane 1 ea.....	21344	x	
2.	O-ring, AQV 1 ea. ....	22623	x	
3.	Roll pin, 1 ea. ....	21164	x	
4.	Flange gasket 2 ea. ....	21322	x	xx
5.	O-ring, 1-1/2" ID 1 ea.....	20267	x	xx
6.	Wiper plunger 1 ea.....	20268	x	xx
7.	Felt disc 1 ea.....	22820	x	xx
8.	Washer, neoprene back 1 ea.....	20196		xx
9.	Washer, 3/4" flat 2 ea.....	03815		xx
(-)	O-ring, 3-1/64" ID MLNM/AQV....	22609		
	(Used with obsolete retaining ring)			
(-)	U-seal, 3-1/2" ID.....	22606		
	(Used only with obsolete aluminum piston)			