

VIBRAHONE™

CB-100



Vibra Finish Company

WWW.VIBRAFINISH.COM

CB-100 — EXPLODED VIEW DIAGRAM

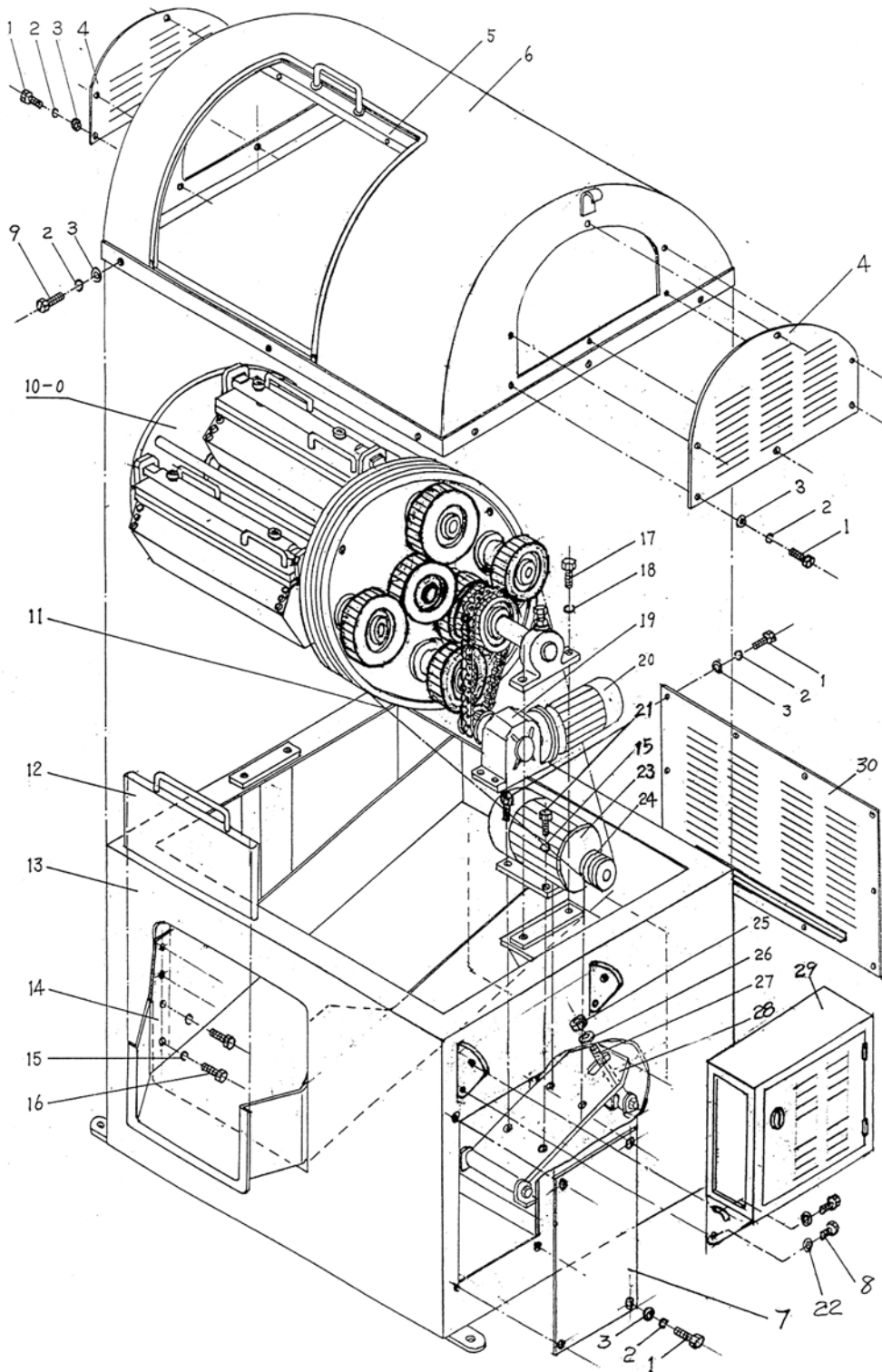

Vibra Finish Company

WWW.VIBRAFINISH.COM

CB-100 — PRIMARY PARTS LISTING
(refer to diagram on page 2 of 5)



ITEM	DESCRIPTION	QTY
1	HEX HEAD SLOT SCREW M6X10	30
2	SPRING WASHER (∅ 6MM)	38
3	FLAT WASHER (∅ 6MM)	38
4	PROTECT PLATE IN UPPER FRAME (1.5MM)	2
5	UPPER FRAME DOOR	1
6	UPPER FRAME	1
7	SIDE PLATE IN UPPER FRAME (1.5MM)	1
8	HEX HEAD BOLTS (M 8X10)	4
9	HEX HEAD SLOT SCREW (M6X15)	4
10-0	TURRET ASSEMBLY	1
11	V BELTS "B" TYPE L=3353	3
12	UNLOAD CHUTE DOOR (3MM)	1
13	BOTTOM FRAME	1
14	UNLOAD CHUTE (3MM)	1
15	SPRING WASHER (∅ 10MM)	8
16	HEX SOCKET HEAD CAP SCREW (M10X20)	8
17	HEX SOCKET HEAD CAP SCREW (M16X40)	4
18	SPRING WASHER (∅ 16MM)	4
19	WORM GEAR SPEED REDUCER (WPDA-70A i=60)	1
20	BARREL MOTOR (Y802-6 0.55KW)	1
21	HEX HEAD BOLTS (M10X35)	4
22	FLAT WASHER (∅ 8MM)	4
23	MAIN MOTOR (YEJ132M ₂ -6 5.5KW)	1
24	MOTOR PULLEY (∅ 160MM)	1
25	HEX NUT (M20)	2
26	FLAT WASHER (∅ 20MM)	2
27	MAIN MOTOR ADJUST SCREW (M20X130)	1
28	MAIN MOTOR BASE	1
29	ELECTRIC BOX	1
30	BACK PROTECT PLATE (1.5MM)	1



Vibra Finish Company

WWW.VIBRAFINISH.COM

CB-100 TURRET ASSEMBLY DRAWING 10-0

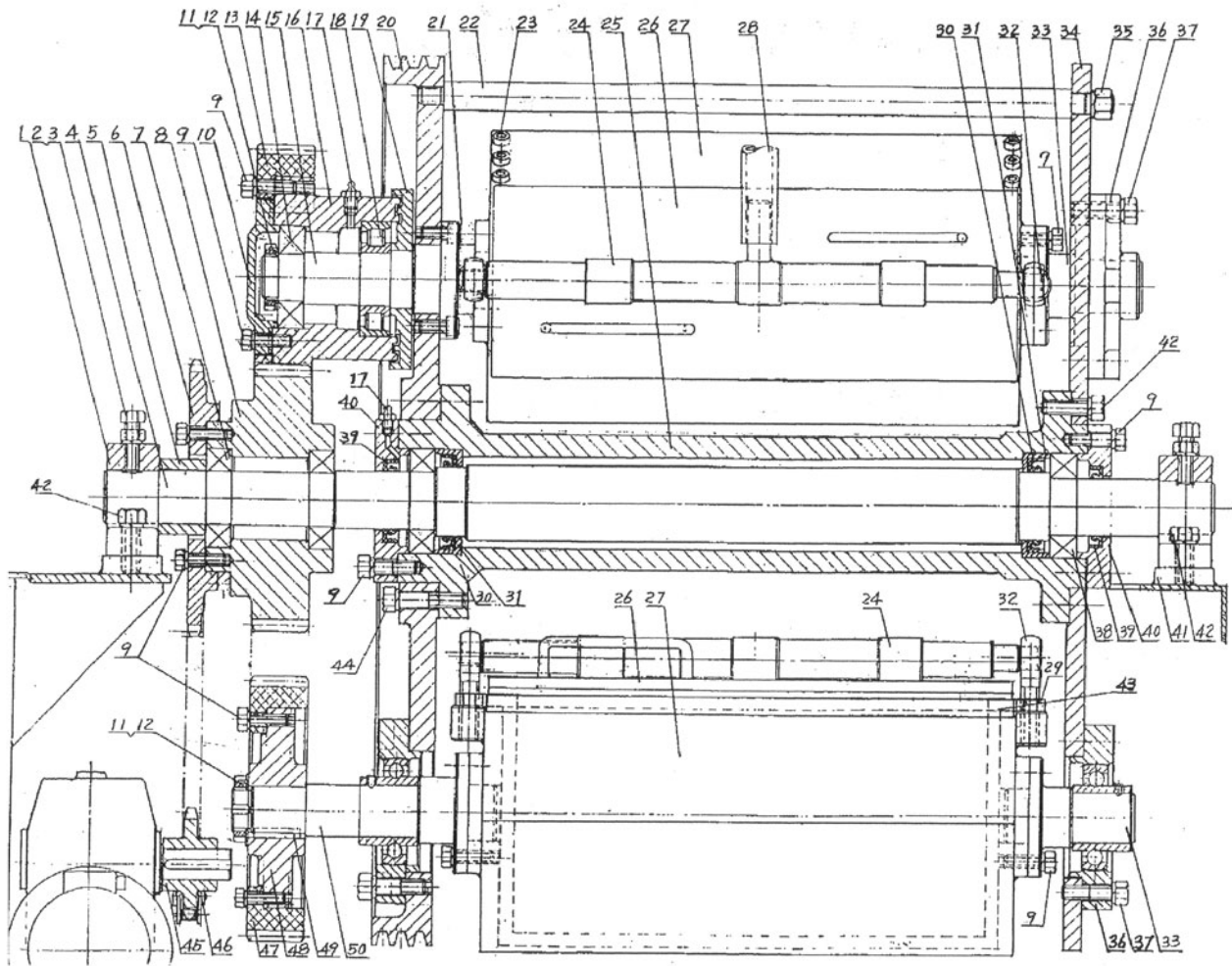

Vibra Finish Company

WWW.VIBRAFINISH.COM

CB-100 TURRET ASSEMBLY — PARTS LISTING 10-0



ITEM	DESCRIPTION	QTY	ITEM	DESCRIPTION	QTY
10-1	SHAFT HOUSE	2			
10-2	HEX HEAD BOLTS (M12X40)	2			
10-3	HEX NUT (M16)	2			
10-4	MAIN SHAFT	1	10-41	SETTING PLATE FOR SHAFT HOUSE	2
10-5	BLOCK SLEEVE	1	10-42	HEX HEAD BOLTS (M1 6X40)	4
10-6	SPROCKET IN MAIN SHAFT (P=19.05 Z=38)	1	10-43	P/U LINING IN BARREL	4
10-7	DEEP GROOVE BALL BEARING SEALED (180219)	2	10-44	HEX HEAD BOLTS (M1 6X65)	4
10-8	GEAR IN MAIN SHAFT (M=4 Z=55)	1	10-45	SPRKT: SPEED REDUCER (P=19.05 Z=15)	1
10-9	HEX HEAD BOLTS (M10X35)	80	10-46	ROLLER CHAIN (P=19.05 L=84PITCH)	1
10-10	COVER FOR TRANSFER GEAR	1	10-47	GEAR IN BARREL SHAFT (M=4 Z=55)	4
10-11	ROUND NUT (M40X1.5)	6	10-48	PLATE FOR GEAR IN BARREL SHAFT	4
10-12	LOCKING WASHER (ø 40MM)	6	10-49	FLAT KEY (A12X45)	4
10-13	TRANSFER GEAR (M=4 Z=55 RIGHT ROTATE)	2	10-50	GEAR SHAFT	4
10-14	DEEP GROOVE BALL BEARING (308)	2			
10-15	SHAFT OF TRANSFER GEAR	2			
10-16	SLEEVE OF TRANSFER GEAR	2			
10-17	OIL NOZZLE (M10X1)	4			
10-18	SINGLE ROLLER BEARING (12309)	2			
10-19	OIL SEAL PLATE	2			
10-20	BELT ROLLER (ø 990MM)	1			
10-21	HEX SOCKET HEAD CAP SCREW (M10X25)	8			
10-22	HOLDING BAR (ø 25MM)	4			
10-23	HEX SOCKET HEAD CAP SCREW (M8X20) S.S.	24			
10-24	LOCKING BAR	4			
10-25	MAIN SHAFT SLEEVE	1			
10-26	BARREL COVER	4			
10-27	BARREL	4			
10-28	PIPE FOR LOCKING	1			
10-29	NUT (M20X1.5) S.S.	8			
10-30	OIL SEAL (70X95X12)	2			
10-31	INSIDE BEARING COVER	2			
10-32	LOCATION SCREW (M20X1.5)	8			
10-33	BARREL SHAFT	4			
10-34	TURRET PLATE (ø 900M)	1			
10-35	NUT (M20)	4			
10-36	FLANGE BEARING (FC209)	8			
10-37	HEX HEAD BOLTS (M1 4X45)	32			
10-38	SELF-ALIGNING ROLLER BEARING (351 2)	2			
10-39	OIL SEAL (60X80X12)	2			
10-40	OUTSIDE BEARING COVER	2			

